

TABEAU DE SURFACES

LOT 4 et LOT 9	T4c	HABITABLE ANNEXE
REZ DE CHAUSSEE		
ABRI VOITURES		15,00
HALL	2,19	
CELLIER	4,30	
WC	1,35	
CUISINE	10,61	
SALON SEJOUR	32,70	
TOTAL	51,15	15,00
COMBLES		
DEGAGEMENT	3,92	
CHAMBRE1 + PI	12,02	
CHAMBRE2 + PI	12,02	
CHAMBRE2 + PI	9,64	
PLACARD	0,46	
SALLE DE BAINS	3,00	
TOTAL	41,06	0,00
TOTAL	92,21	15,00

T4 →

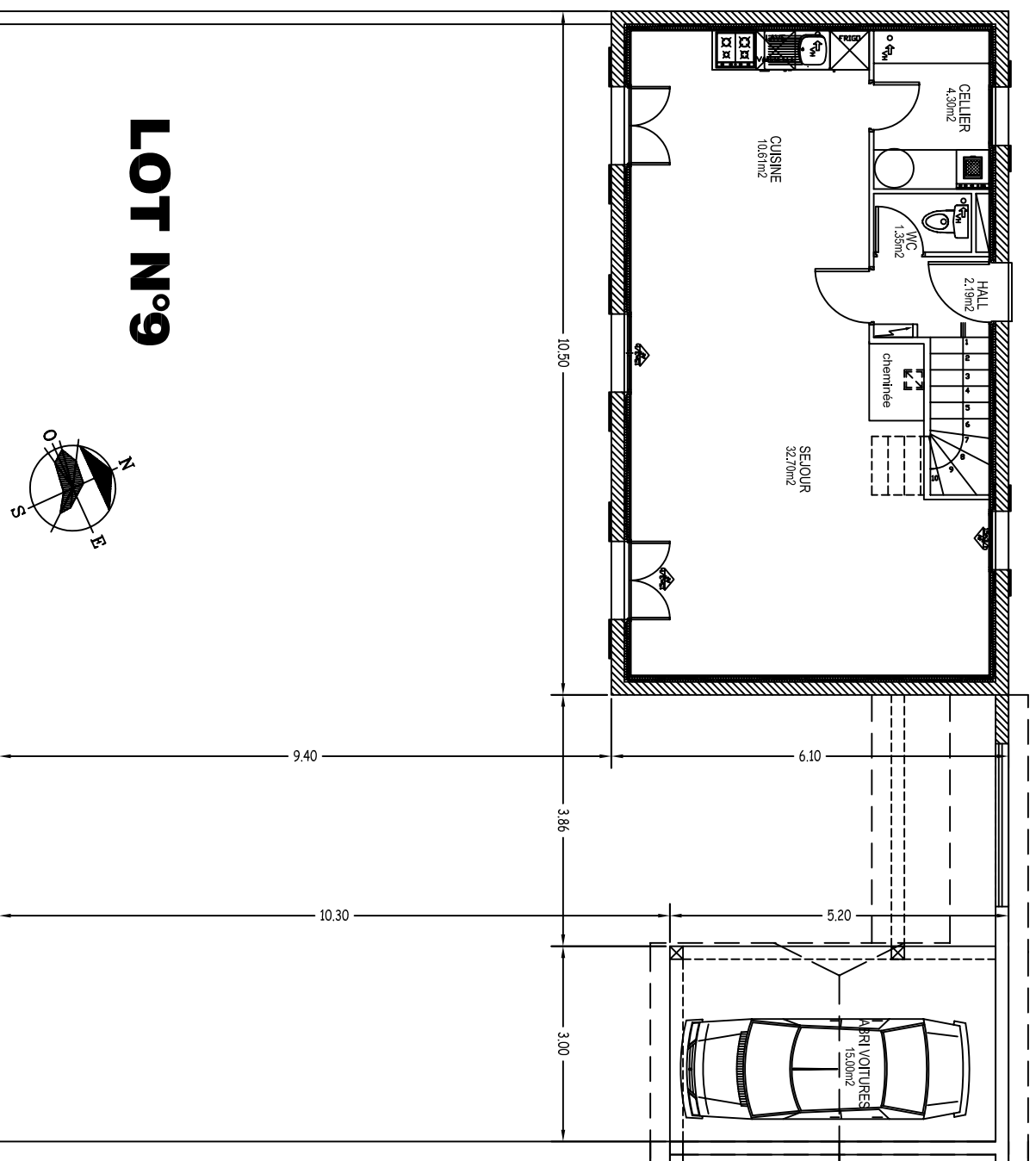

LOT N°9

REZ DE CHAUSSEE

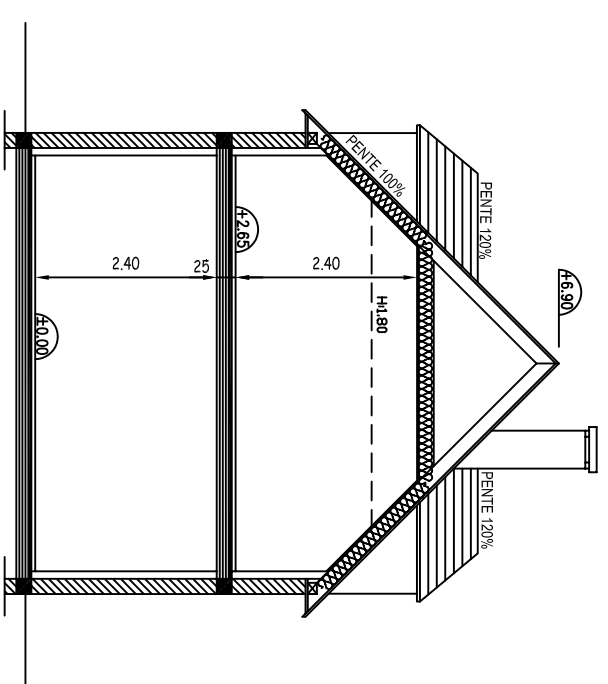

COUPE

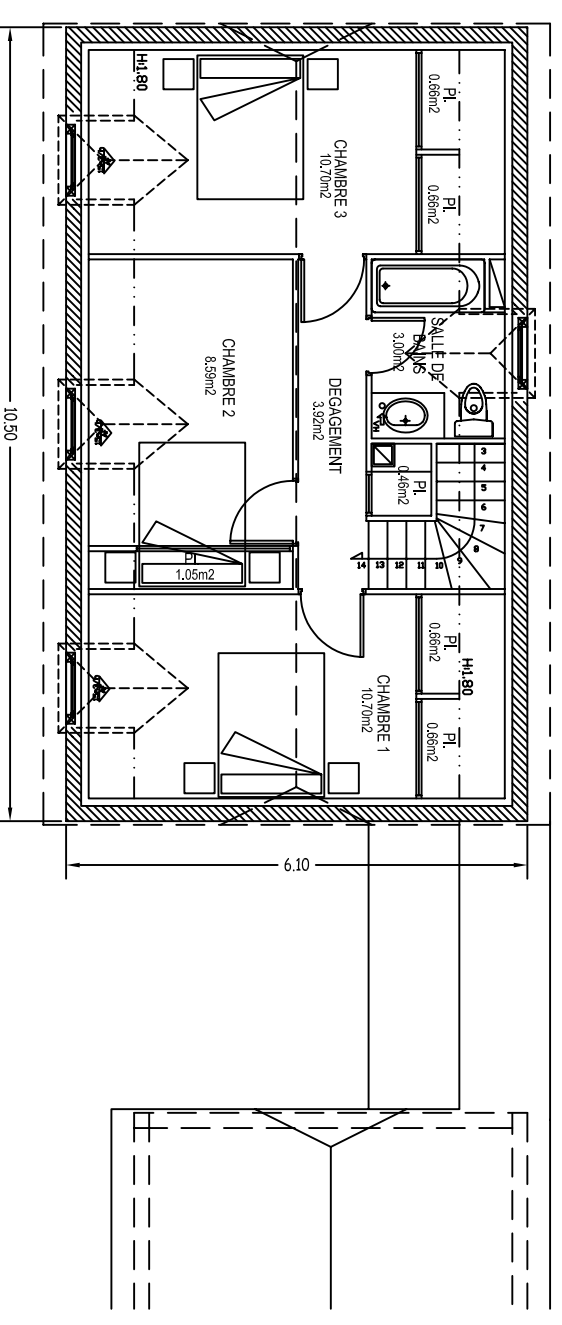

ETAGE